

EN

Air Fluidised Care System(s)

Instruction for Use



&



CE 0344



Synergie. Advanced
Patient Support

Synergie Nederland BV
Sterrekroos 6
4941 VZ RAAMSDONKSVEER
The Netherlands
Tel.: +31 162 677227
E-mail: info@synergiecare.com
Internet: www.synergiecare.com

© Copyright 2023

All rights reserved. Nothing from this edition may be multiplied, or made public, in any form or manner, either electronically, mechanically, by photocopying, recording, or in any other manner, without prior written consent from Synergie Nederland BV. This also applies to the accompanying drawings and diagrams.

Synergie Nederland BV reserves the right to change parts at any given moment and without prior or direct notification of the client. The contents of these service instructions may also be changed without warning. For information on settings, maintenance or repairs not provided by these service instructions, please contact your supplier's technical service department.

These service instructions are compiled with the greatest possible care. Nonetheless, Synergie Nederland BV cannot accept any responsibility for possible errors in these service instructions or for any resultant consequences.

Table of contents

TABLE OF CONTENTS	3
PREFACE	5
WARRANTY	6
DISPOSAL	6
DIMENSIONS AND IDENTIFICATION PEARLS™	7
PEARLS™ AFC GENERAL DIMENSIONS [MM]	7
DIMENSIONS AND IDENTIFICATION SANDS™	9
SANDS™ AFC GENERAL DIMENSIONS [MM]	9
IDENTIFICATION LABELS PEARLS™	11
IDENTIFICATION LABELS SANDS™	12
EXPLANATION OF LABEL SYMBOLS	13
GENERAL SAFETY REGULATIONS	17
INTENDED USE	20
ENVIRONMENT	20
INTENDED USER PROFILE	20
AFC PRINCIPLE	21
CLINICAL BENEFIT SPECIFICATIONS	21
CLINICAL INDICATIONS	21
CLINICAL CONTRA-INDICATIONS	21
CONTROL FUNCTIONS AFCS	22
HEIGHT ADJUSTMENT.....	22
PEARLS™ CENTRAL BRAKE	23
PEARLS™ STEERING SYSTEM	23
PEARLS™ CONDENSATION WATER OUTLET (COOLING EQUIPMENT)	24
SANDS™ BRAKES.....	25
SANDS™ STEERING SYSTEM	25
AFCS LEVEL ADJUSTMENT SYSTEM.....	26
GRAPHICAL USER INTERFACE (GUI)	27
PREPARING AFCS FOR PATIENT TREATMENT:	27
SET TEMPERATURE.....	31
AIRFLOW INTENSITY	34
SETTING PULSATION (AVAILABLE FOR PEARLS™ ONLY).....	37
PATIENT TREATMENT TIMER.....	41
NURSING THE PATIENT	42
SIDE POSITION	42
AIRFLOW ADJUSTMENT FOR DIFFERENT PATIENT WEIGHTS	42
EXTRA AIRFLOW FOR REPOSITIONING	43
CPR	44
FITTING A CLEAN SHEET	45
PREVENTION OF “HAMMOCK EFFECT”	46
OINTMENTS CAUTION:	46
ACCESSORIES AFCS.....	48
<i>Adjustable backrest (manually adjustable)</i>	48
<i>Adjustable footrest (manually adjustable)</i>	48

<i>Traction support pole (including triangle)</i>	48
<i>Traction support frame (including triangle, infusion pole)</i>	49
<i>Extension hose (maximum 6 m (19.68 ft) in length)</i>	49
ALARMS AND WARNINGS	50
SAFETY WARNINGS	50
<i>40°C (104°F) Alarm</i>	50
<i>Temperature delta</i>	51
<i>Air pressure drop</i>	51
<i>Cooler / Heater faulty condition</i>	52
<i>Sensor faulty condition</i>	52
<i>Info warning</i>	53
SERVICE ALERTS.....	53
CLEANING AND DECONTAMINATION	54
PREVENTIVE MAINTENANCE	55
PRE USE MAINTENANCE	55
<i>Air filter</i>	55
<i>Filter sheet</i>	56
<i>Condenser</i>	56
<i>Condensation water drain system</i>	56
TROUBLESHOOTING	57
APPENDIX PEARLS™	58
TECHNICAL SPECIFICATIONS	58
<i>General</i>	58
<i>Electrical / Electronic specifications</i>	58
<i>Mechanical Specifications</i>	58
<i>Acoustic specifications</i>	59
APPENDIX SANDS™	60
TECHNICAL SPECIFICATIONS	60
<i>General</i>	60
<i>Electrical / Electronic specifications</i>	60
<i>Mechanical Specifications</i>	60
<i>Acoustic specifications</i>	61
APPENDIX AFCS	62
TECHNICAL SPECIFICATIONS	62
<i>Protection</i>	62
<i>Essential performance</i>	62
<i>Applied Parts</i>	62
<i>None applied parts (regarded as)</i>	62
<i>Operator parts</i>	62
<i>Environmental conditions</i>	62
<i>Transport:</i>	63
<i>Standards/Environment</i>	63
<i>Accessories (optional parts)</i>	63
<i>Service parts (Consumables)</i>	63
APPENDIX PARTS PEARLS™	64
PEARLS™ AFCS MAIN PARTS LIST	64
APPENDIX PARTS SANDS™	65
SANDS™ AFCS MAIN PARTS LIST	65

Preface

This instruction describes the use of Air Fluidised Care Systems (AFCS). The information in this instruction is important for the proper and safe functioning of the device. If you are not familiar with the operation, preventive maintenance, etc. of the AFCS, then read this instruction thoroughly from the beginning to the end. If you are familiar with the AFCS, you can use these instructions for reference. The required information can be easily found using the table of contents and the keyword index.

In this Instruction, below marking conventions are used to focus attention on certain subjects or actions.



ATTENTION:

A remark with additional information; attention to possible problems



CAUTION:

The device may be damaged if you do not execute the procedures carefully



WARNING FOR DANGER:

You can (seriously) hurt yourself or others if not executed the instructions carefully



WARNING FOR DANGER:

Beware of electrical shock hazard while working beneath the power supply

This instruction describes 2 models of AFCS - PEARLS™ (SAT2) and SANDS™ (SAT1). Both products use the same principle and have the same intended use. Where applicable differentiation is described.

Warranty

Our warranty clauses and the stipulations regarding liability are addressed in our Warranty Certificate.

Disposal

Follow local governing ordinances and recycling plans regarding disposal of the product or components normally used in operation. The product does not generate waste or residue in operation. Any accessories not part of the product must be handled in accordance with the individual product marking for disposal.

This product has been supplied from an environmentally aware manufacturer that complies with the waste Electrical and Electronic Equipment (WEEE) Directive 2012/19/EU.

This product may contain substances that could be harmful to the environment if disposed of in places (landfills) that are not appropriate according to legislation.

Please be environmentally responsible and recycle this product through your recycling facility at its end of life.

End of life AFCS: 10 years after production date.

Dimensions and Identification PEARLS™

PEARLS™ AFC general dimensions [mm]

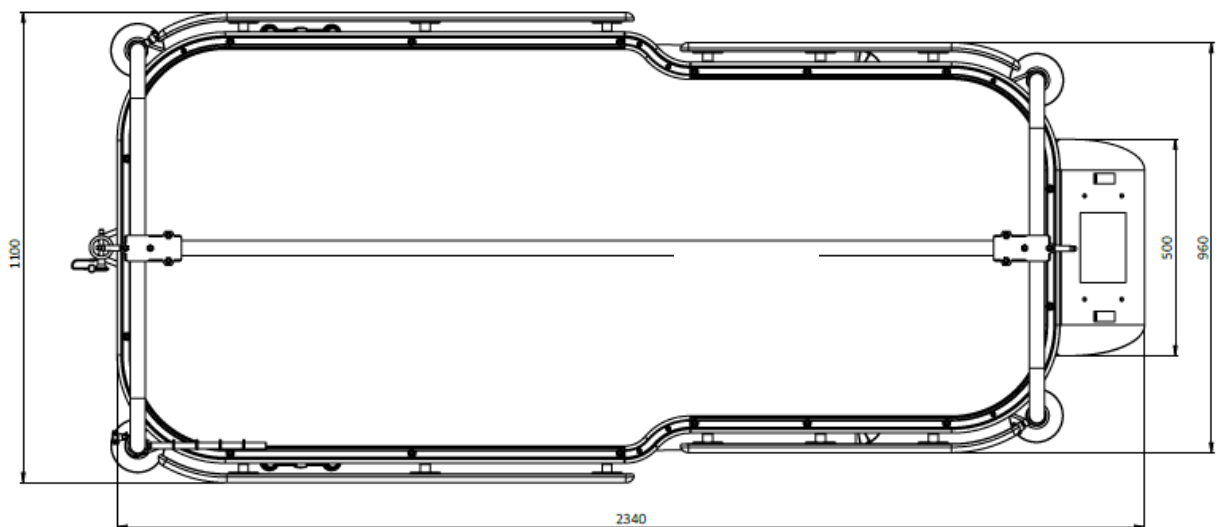
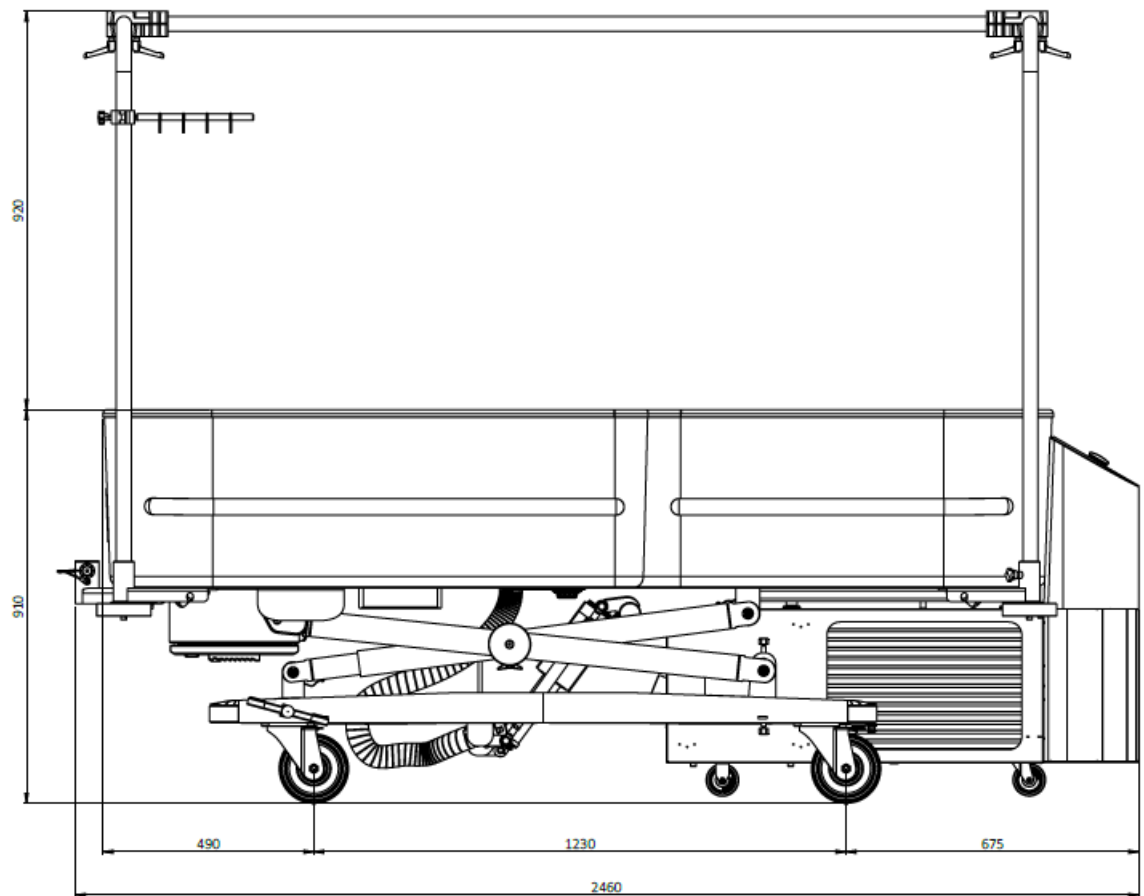

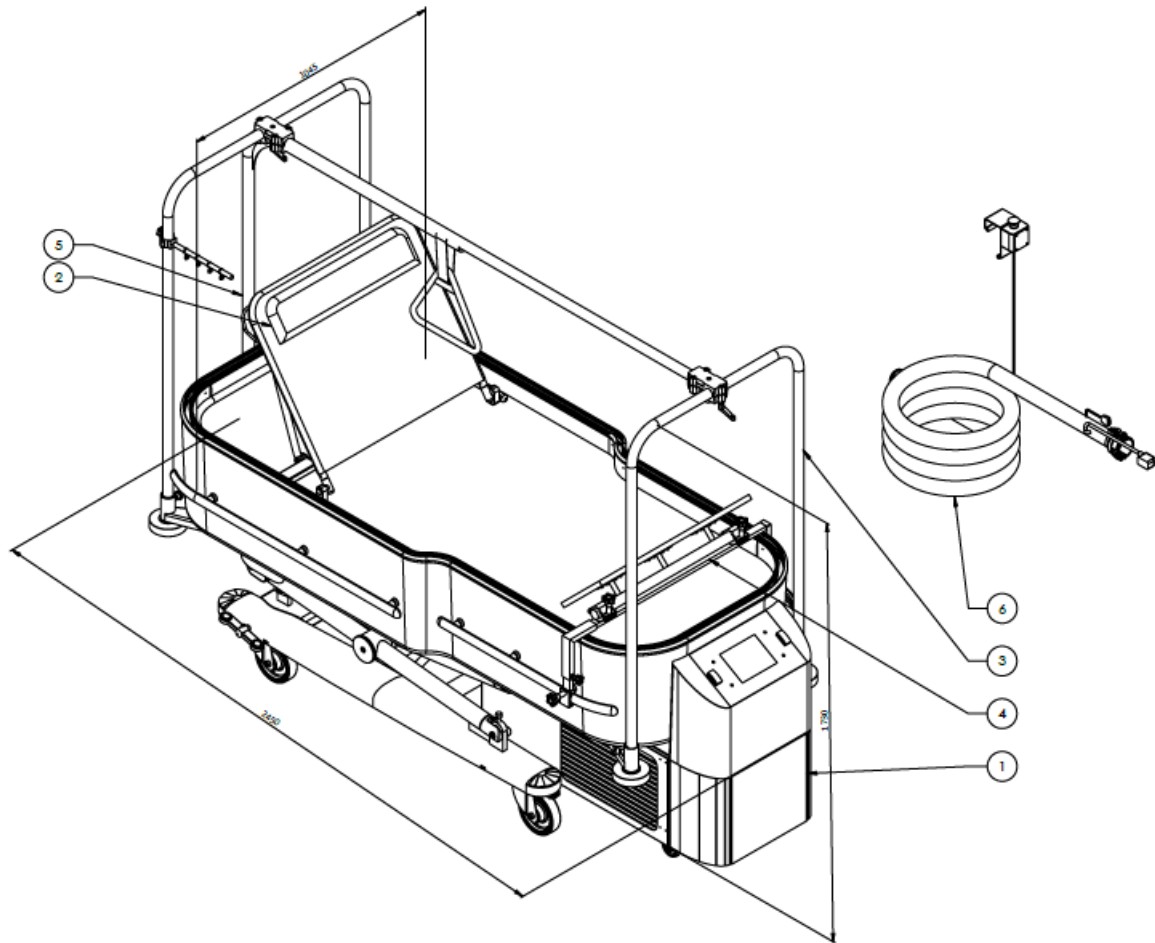

Weight AFCS:

Total PEARLS™ AFC System: approx. 960 kg (2116 lbs)

Detachable control unit: approx. 110 kg (243 lbs)

The Air Fluidised Care System (including accessories, see appendix Parts)

6	Extension Hose
5	Traction Support Pole
4	Footrest (Manually Adjustable)
3	Traction Frame
2	Manually Adjustable Backrest
1	AFCS
Item	Description

Dimensions and Identification Sands™

SANDS™ AFC general dimensions [mm]

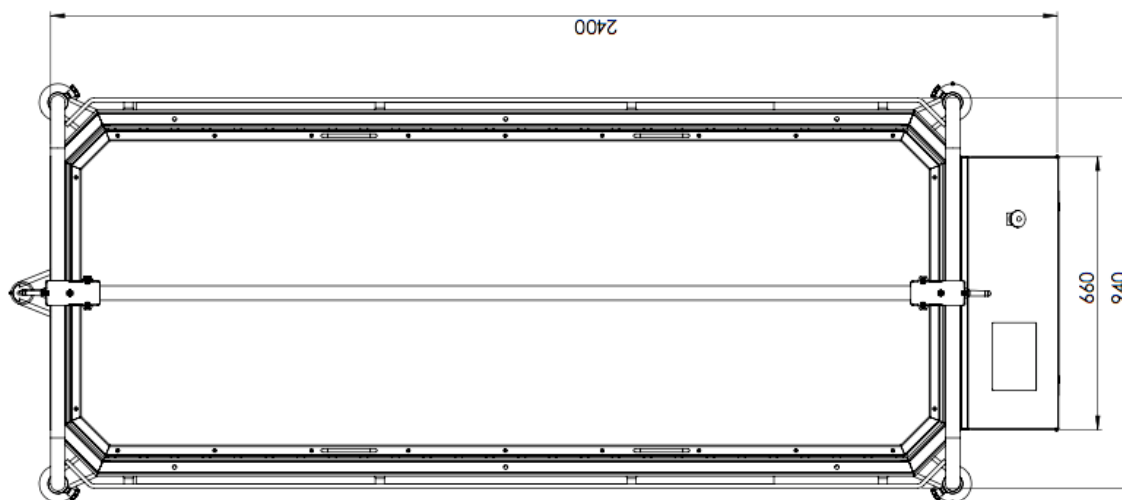
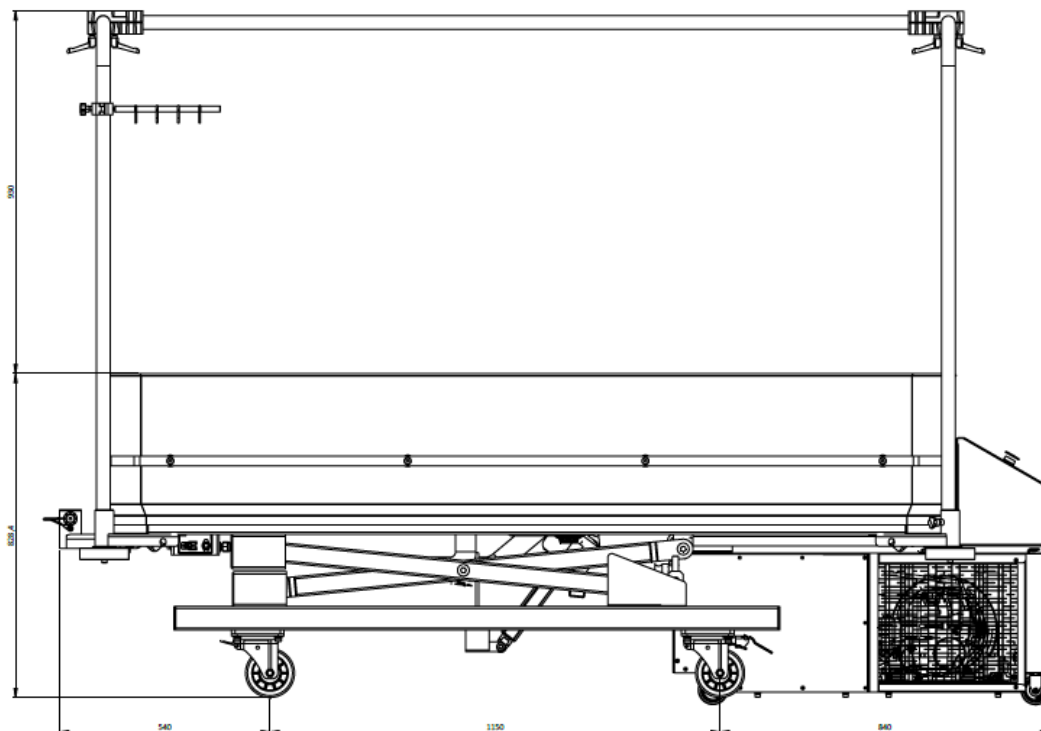

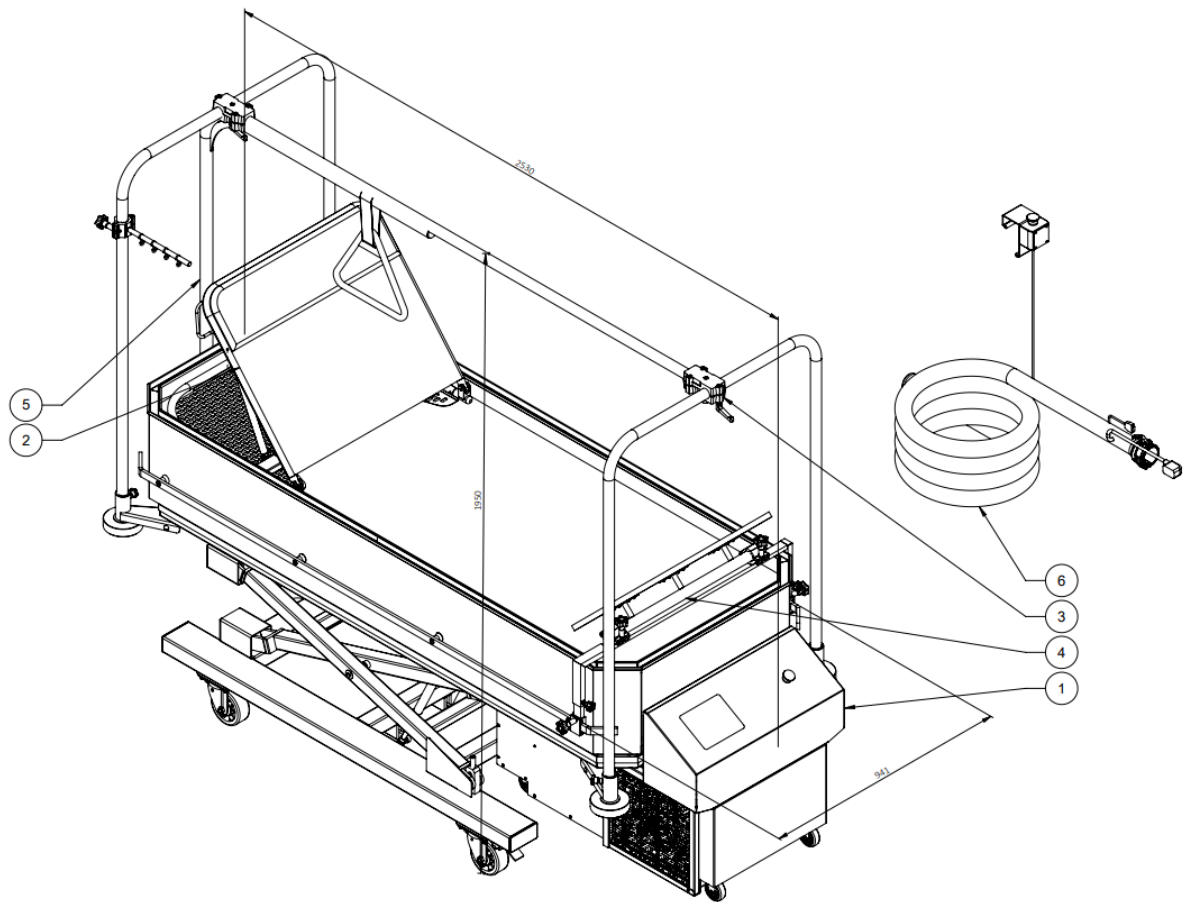

Weight AFCS:

Total SANDS™ AFC System: approx. 940 kg (2072 lbs)

Detachable control unit: approx. 105 kg (231 lbs)

The Air Fluidised Care System (including accessories, see appendix Parts)



6	Extension Hose
5	Traction Support Pole
4	Footrest (Manually Adjustable)
3	Traction Frame
2	Manually Adjustable Backrest
1	AFCS
Item	Description

Identification labels PEARLS™

Control unit label



Synergie PEARLS™ CONTROL UNIT
Air Fluidised Care System Model : SAT2

SN 20xxx
REF 2010002

MD  0344  

230 v 50 Hz 1700 VA

 Synergie Nederland BV
Sterrekroos 6
4941 VZ Raamsdonksveer
The Netherlands
www.synergiecare.com

 **UDI**
 110 kg 

(01) : 08720387388165
(11) : yyyy-mm-dd
(21) : 20xxx



EC **REP** Name
Address
Country

LABxxxx.2

Bed unit label



Synergie PEARLS™ BED UNIT
Air Fluidised Care System Model : SAT2

SN 25xxxx
REF 2010003

MD  0344  

230 V 50 Hz 1700 VA

 Synergie Nederland BV
Sterrekroos 6
4941 VZ Raamsdonksveer
The Netherlands
www.synergiecare.com

 **UDI**
 15-150 kg 







 850 kg (01) : 08720387388189
(11) : yyyy-mm-dd
(21) : 25xxx

EC **REP** Name
Address
Country









LABxxxx.2

Identification labels SANDS™

Control unit label

Synergie		SANDS™ CONTROL UNIT	
Air Fluidised Care System Model : SAT1			
SN	10xxx	MD	CE 0344  
REF	1010402		230 v 50 Hz 1725 VA
	Synergie Nederland BV Sterrekroos 6 4941 VZ Raamsdonksveer The Netherlands www.synergiecare.com		UDI
	yyyy-mm-dd	 105 kg	 (01) : 08720387388233 (11) : yyyy-mm-dd (21) : 10xxx
EC	REP	Name Adress Country	
			LABxxxx.2

Bed unit label

Synergie		SANDS™ BED UNIT	
Air Fluidised Care System Model : SAT1			
SN	15xxx	MD	CE 0344  
REF	1010403		230 V 50 Hz 1725 VA
	Synergie Nederland BV Sterrekroos 6 4941 VZ Raamsdonksveer The Netherlands www.synergiecare.com		UDI
	yyyy-mm-dd	 15-135 kg  835 kg	 (01) : 08720387388240 (11) : yyyy-mm-dd (21) : 15xxx
EC	REP	Name Adress Country	
			LABxxxx.2









Explanation of Label Symbols





















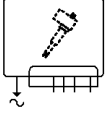

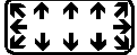

WARNING FOR DANGER:

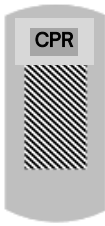

Regularly check if all labels on the device are still in place; if not, replace them

There are several labels affixed onto the device and/or its accessory, to warn the user of remaining risks that may be present despite the safe design. Check regularly to see whether all labels are still at the correct place. If not, replace them.

Symbol	Description	Location
	Indicates the medical device manufacturer	Bed unit and control unit ID tag.
	Indicates the date when the medical device was manufactured	Bed unit and control unit ID tag.
	Indicates the manufacturer's Catalogue number so that the medical device can be identified	Bed unit and control unit ID tag.
	Indicates the manufacturer's Serial number so that a specific medical device can be identified	Bed unit and control unit ID tag.
	Unique device identifier	Bed unit and control unit ID tag
	Authorized representative in the European Community / European Union	Bed unit and control unit ID tag if applicable
	CE marking: Indicates that Synergie Nederland complies with European Medical Device Regulation. (0344 Notified Body id)	Bed unit and control unit ID tag.
	Indicates the item is a medical device	Bed unit and control unit ID tag.
	Refer to instruction manual/ booklet	Bed unit and control unit ID tag.

	Electricity hazard Access for technically skilled personnel only.	Back plate of the control unit and inside the control unit.
	Hot surface	Control unit near any hot parts.
	Entrapment of hands	Near moving parts or between moving parts and fixed parts - e.g., the scissor/lifting table.
	General warning sign	Outer bin AFCS, Transformer box BU, Remote control high/low.
	Tripping Hazard	Extension Hose
	Type B applied part (IEC 60417-5840)	Bed unit and control unit ID tag.
	Maximum body weight	Bed unit and control unit ID tag.
	Waste symbol WEEE	Bed unit and control unit ID tag.
	Weight of the unit	Bed unit and control unit ID tag.
	No drinking water	Water collection can of PEARLS Control Unit (Accessory PEARLS)
	Connection of the actuator (high/low)	Bedframe (near main power outlet to control unit)
	Data input / output	Bedframe (near main power outlet to control unit)
	Pressure sensor	Next to junction box bed unit

	Temperature sensor	Junction box bed unit
%RH 	Humidity Sensor	Junction box bed unit
 220V-230V	Main power	Junction box bed unit
	CPR button (Cardio Pulmonary Resuscitation)	On top of control unit
	CPR button (Cardio Pulmonary Resuscitation)	On top of control unit
	USB (Universal Serial Bus) for connecting auxiliary device (USB stick)	Control unit
	Earth potential connector	Control unit. Next to main power inlet
	Decontamination key switch ON / OFF	Junction box bed unit
	Footswitch connection	Footswitch
ON/OFF	Footswitch ON / OFF	Footswitch
REPOSITION	Footswitch Reposition	Footswitch
	Hand switch for starting the fluidization	Junction box bed unit

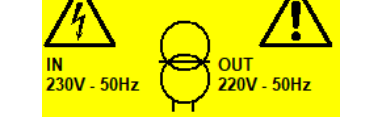
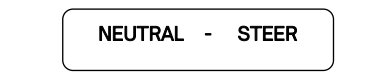
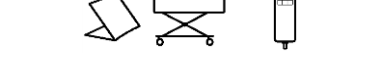
	<p>Warning High/Low adjustment</p> <p>Detachable control unit</p>	<p>Outer bin of the bed unit, Foot end side, close to the control unit.</p>
	<p>Warning High/Low adjustment</p>	<p>Remote control</p>
<p>SWL</p>	<p>Safe Working Load</p>	<p>Backrest, Traction Pole, Traction Frame</p>
	<p>Separation Transformer</p>	<p>Transformer box of the bedframe main power IN</p>
	<p>NEUTRAL position - STEER position of the wheels</p>	<p>Located at the castors of the Pearls bed unit foot end.</p>
	<p>Backrest-Actuator- Remote control</p>	<p>Positioned at the Box Control Unit</p>

General safety regulations



WARNING FOR DANGER:

You can (seriously) hurt yourself or others if not carefully executed the procedures



WARNING FOR DANGER:

Beware of electrical shock hazard while working under power supply

- Before you perform any action in connection with the AFCS, read this user's manual carefully. Synergie Nederland BV is not liable for injury, damage and/or excessive wear resulting from incorrect performed maintenance, incorrect use or modifications to the device.
- The AFCS safety solutions may not be extended, adapted, or altered without written consent from Synergie Nederland BV. Do not remove or mute safety devices.
- Everyone working with this device must be familiar with the control systems.
- Emphasize these safety regulations during training before using. Provide a clean and safe workplace.
- Repairs or maintenance to the device shall be performed by authorized personnel only.
- Lifting the control unit requires a lifting table.
- The floor of the room where the system is installed shall be designed for loads of at least 500 kg/m² (102,5 lbs/ft²).
- Patients are NOT to be transported in the bed. The bed may be moved only under the supervision of trained (Service) personnel.
- Stand clear of the basin and control unit when lowering the system to its minimum height setting.
- Never move the Air Fluidised Care System in aisles with tight corners when the control unit is attached to the bed unit.
- If a patient weighing (>150 kg (330 lbs)) or a patient with excessive exudate is being treated, the AFCS can no longer accurately control the process of fluidization and temperature control. The performance will be compromised but no hazardous situations will occur.
- If the patient loses excessive amounts of exudates, it is likely that the Care will not completely meet expectations without using extra absorbent pads.
- The patient will be lifted or sink slightly when the airflow is switched on/off. Take extra care with ventilated patients to prevent disconnections of respiratory tube.
- To avoid the risk of electric shock, this equipment shall be connected only to a main power source with protective grounding. (Class I ME Equipment (IEC60601-1))
- Patients suffering from dementia, agitated, or in a confused state may use unpredicted force to get off the AFCS or cause an unexpected dangerous situation. Caregivers protocol for this patient group should clearly decide whether an individual can be treated on the AFCS safely.
- For nursing children/patients <15 kg (33 lbs), take care to use a filter sheet with an open mesh size to prevent blowing the filter sheet.
- Take great care small children will not climb off the bed or are too active while being treated.
- Patients with pulmonary congestion should not be treated in flat lying position for long periods of time or should consider treating them in a prone position.
- Take care that during the decontamination cycle (only executed by trained personnel) no patient is on the AFCS.

- Protective equipment – gloves, air filter mask, goggles, aprons, and overalls must be worn when working with contaminated beads.
- Beware of beads dropping on the floor. It could be slippery when the filter sheet and sieve are removed or when clean beads are transferred from its packing to the bed basis
- In the event glass beads escape:
 - with eye contact as a result: Irrigate with eyewash solution or clean water, holding the eyelids apart, for at least 15 minutes. If symptoms persist, get medical attention.
 - with skin contact as a result: Wash the affected skin with plenty of water. If symptoms occur, get medical attention.
 - with inhalation as a result: Move the individual to fresh air and keep them calm. If symptoms develop, get medical attention.
 - with wound contact: Wash the wound with lukewarm water. If symptoms occur, get medical attention.
- Patients waking up after a vegetative state may feel uncomfortable or immobile in the AFCS as they may experience floating. A rehabilitation plan should be considered.
- Patients treated on an AFCS will dehydrate due to the constant ventilation; take good care of the patient's fluid balance.
- Take care the AFCS is at the right temperature when therapy starts. Consult with medical for the correct temperature for each patient.
- Any serious incident that occurs in relation to this device should be reported to the manufacturer and the corresponding authority of the State in which the user and/or patient is treated.



CAUTION:

The device may get damaged if you do not carefully execute the procedures

- When using wound-healing drugs, check if they are suitable for the treatment or use an absorption sheet (only air-ventilating types). Oil-containing drugs will degrade the glass beads, rendering the system useless.
- Do not allow sharp objects to be in direct contact with the filter sheet. Scissors, knives, sharp fingernails, safety pins etc. can damage the filter sheet and render it ineffective. The glass beads will flow through the tear and could get into the wounds; the AFCS could then eventually fail to operate. Switch off the device immediately and ask skilled service staff to determine whether the filter sheet was inadvertently damaged.
- When handling the system or applying pressure to parts of the system or its packaging, take great care not to damage the framework or the control unit or to damage fragile fixtures and fittings such as the basin-lifting mechanism.
- All vacuum cleaners used in decontamination shall not be used for any other purpose and should be fitted with a HEPA grade filter.
- Ensure that all cables and connectors are clear of working parts and are not trapped under the unit before use.
- Ensure brakes are effectively locked after installation is completed.
- Always leave the bed with fluidization/conditioned airflow activated after the patient has been removed until decontamination has been performed in order to prevent bacterial growth.
- For all transportation purposes outside the hospital, the basin's weight must be supported with four transit support poles.
- Health and safety guidelines regarding lifting are to be followed when handling this product.
- For optimal use, at least 50 m³/hr (17652 ft³/hr) fresh air should be ventilated into the room where the AFCS control unit is placed.
- If the touch screen panel is cleaned the menu may be changed inadvertently. Check to ensure that the AFCS is still working properly.
- Be aware of the safe working load of the traction pole and the traction frame $\leq 750\text{N}$.
- The electronics and temperature sensor needs regular calibration.

Intended Use

Air Fluidised Care (also known as Air-Fluidized Therapy/AFT) is an optimal healing environment that supports patients with conversion of tissue caused by burns, bedsores, ulcers and other exuding wounds as well as patients that require rest in a stable, clean environment to avoid complications.

Air Fluidised Care guarantees extremely low interface pressure and encapsulation of bacteria combined with continuous temperature control and dry ventilation around the patient's body. These circumstances will secure the environment to improve healing and prevent unexpected complications.

Environment

The AFC is intended for providing care in a hospital or other medical facility where medical supervision and monitoring is required and for maintaining or improving the condition of the patient.

Intended User Profile

This manual is intended for qualified personnel with an understanding of how to use this device. All installation, service, maintenance, and troubleshooting are to be executed by technically skilled personnel. A service manual is available for these activities.

By 'qualified personnel', we mean personnel who:

- Have a particular level of knowledge due to previous education/training (specific training).
- Have the level of experience required to work with the device (for instance an operator).

By 'technically skilled personnel', we mean qualified personnel who:

- Have a particular level of technical knowledge (at least high school level) by education/training.
- Are familiar with the technology used in the machine and who perceive the potential dangers (a service mechanic, for example).



WARNING FOR DANGER:

Installation, periodic maintenance, and repairs shall be performed by personnel who are technically skilled only, unless otherwise indicated.

By 'operating', we mean:

- Operational adjustments.
- Working with the device, cleaning, and performing simple maintenance.

The goal/function of these instructions is to create a safe and efficient interaction between people and device.

AFC Principle

A patient is kept floating on a mass of tiny glass beads which are ventilated at low pressure by a conditioned airflow. The resulting support medium can be characterized as a “dry fluid” and is known as the “air fluidisation principle”.

The surface of the glass beads is separated from the patient by a generously proportioned filter sheet and hospital sheet that allow the patient to “float” freely.

The principle is to create perfect envelopment of any individual body shape and redistribute the weight evenly, resulting in extremely low interface pressure, below capillary level.

The composition of the glass beads (high pH value) in combination with a dry airflow rapidly reduces the bacterial growth in the AFC.

To diminish any risk of cross-infection between patients, a thermal decontamination/disinfection feature has been integrated into the AFCS.

Clinical benefit specifications

- AFCS provides a significant reduction in interface pressure compared to other types of support systems
- AFCS contains a dehumidifying mechanism to “dry” the air and minimize the growth of organisms in the wounds
- AFCS allows the healing of damaged tissue or prevents the loss of healthy tissue by minimizing pressure on the skin and reducing bacterial growth
- The effect of the AFCS medium on the skin supports the treatment of patients with highly exuding wounds.

-

Clinical indications

Typical uses of AFC include:

- Support for burns patients
- Treatment of all stages of pressure ulcers
- Treatment of flaps and grafts or other plastic surgery wounds
- Support for multiple trauma patients
- Cachexic patients
- Other types of skin disorders
- Immobility related to injury or therapy (but see exceptions listed below)
- Prone position of ARDS patients.

Clinical Contra-indications

- Unstable spine
- Nursing a non-ventilated patient in the prone position
- Drugs, creams, and wound dressings that contain petroleum-based products which will make the air fluidisation process ineffective
- PEARLS™ Weight of the patient is <15 kg or >150 kg* (33-330 lbs)
- SANDS™ Weight of the patient is <15 kg or >135 kg* (33-298 lbs)

** Conditional: depending on the surface of wounds and the loss of exudates, the maximum weight to be supported will decrease.*

Control Functions AFCS



WARNING FOR DANGER:

Prior to use with a new patient, ensure that the AFCS has been decontaminated; ask the service staff or rental partner to provide for proper paperwork.

Inspect the device for external damage and functionality.

Height adjustment

The AFCS can be equipped with an adjustable height system. This system moves the basin smoothly to the required height for treating or nursing a patient.

The high/low system is operated via a hand-held operating console fitted with two push buttons.



PEARLS™



SANDS™



WARNING FOR DANGER:

When raising/lowering the bed unit for ventilated patients, take great care to prevent disconnecting the tubes.



WARNING FOR DANGER:

Please note not to pinch any limbs when raising and lowering the bed.

PEARLS™ Central brake

The PEARLS™ AFCS unit is equipped with a central brake at the head-end of the bed unit. The pedals are activating the brakes in both directions. In the middle position the brakes are released.

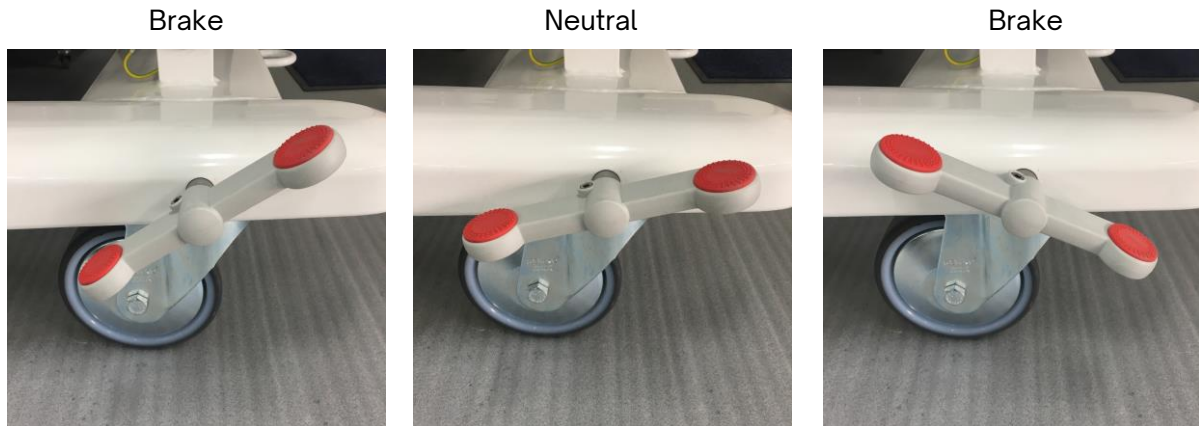

WARNING FOR DANGER:

Only release the brake during transport / movement of the bed. In all other situations use the central brake to secure that the unit cannot move unattended

PEARLS™ Steering system

The PEARLS™ AFCS unit is equipped with a steering system on 2 castors at the bed unit foot end.

In NEUTRAL position all four wheels can turn and swivel. In STEER position the 2 castors at the foot end are locked. The bed can then be transported in a straight line.



WARNING FOR DANGER:

Increase the height of the bed to assure that the swivelling front wheels cannot touch the Control Unit while moving in NEUTRAL position

PEARLS™ Condensation water outlet (cooling equipment)

The AFCS unit is equipped with an integrated cooling system to precisely regulate the bed temperature and lower the relative humidity. The condensation water of this equipment is internally evaporated.

During periods of high humidity it might occur that there is an overflow of condensation water leaving the evaporator. This water will drip from a plastic tube outside the left side panel. This is a normal behaviour of the air conditioning system.

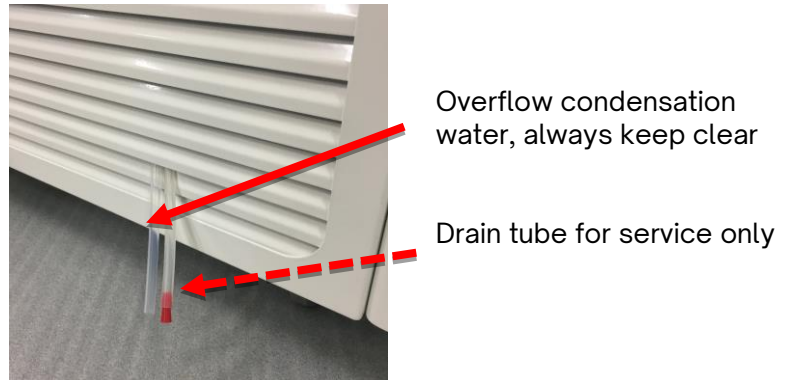

Place a water collection can under the outlet to prevent water dripping on the floor.

An collection can is available that can be mounted to the Control Unit (item 2010318).



WARNING FOR DANGER:

The condensation water is hot when leaving the tube. Avoid direct contact



ATTENTION:

Make sure the tubes are always outside the side panel and do not block the plastic tube as the water will cause overflow within the Control Unit

SANDS™ Brakes

The SANDS™ AFCS unit is equipped with brakes at two castors at the head end side of the bed unit.



WARNING FOR DANGER:

Only release the brake during transport/movement of the bed. In all other situations use the brake to secure that the unit cannot move unintendedly

SANDS™ Steering system

The SANDS™ AFCS unit is equipped with a castors at the head and foot end of the bed.

In NEUTRAL position all four wheels can turn and swivel. In STEER position the 2 castors at the foot end side are locked. The bed can then be moved in a straight line.



WARNING FOR DANGER:

Increase the height of the bed to assure that the swivelling front wheels cannot touch the Control Unit while moving in NEUTRAL position

AFCS Level adjustment system

To optimize the temperature distribution and the fluidization in the basin, the AFCS is provided with a level adjustment system. The fluidization is influenced by the flatness of the floor where the system is used.

PEARLS



SANDS



It is recommended that the fluidization is checked after every location change. The basin position should be adjusted as needed. Also, before activating decontamination cycle, the fluidization should be checked to optimize decontamination.

The level adjustment system is used by loosening the bolts at the front sides of the basin from below or from above (whichever is needed) and by turning the counter bolts respectively. This adjusts the scissor frame, which adjusts the basin position.



ATTENTION:

Adequate airflow is needed to keep the interface pressure low.



ATTENTION:

Check out the service manual to secure correct operation.

Graphical User interface (GUI)

Preparing AFCS for patient treatment:

Before starting the device, the following instructions need to be clearly understood:



ATTENTION:

Buttons with adjustment options are marked with a framework:

PEARLS	SANDS

Buttons without framework only display a value:

PEARLS	SANDS

Warnings are marked with a color or are blinking on the screen:



ATTENTION:

If the adjustment button is pressed correctly, it will turn green.



ATTENTION:

A time delay is provided in the push buttons to prevent unwanted setting changes. Default is 10 seconds. This time can be adjusted in the service menu.

As soon as the mains power plug is connected, the controller will start up and two acoustic signals will be heard.

The display shows the booting announcement; it will take approx. 15 seconds before it is ready for use. Start the system by pressing:

PEARLS



SANDS



The HOME menu will become visible, and the actual temperature will appear on the display.

PEARLS



SANDS



The timer will start a 30-minutes countdown starting the airflow automatically if not activated by the foot/hand switch.

PEARLS



SANDS

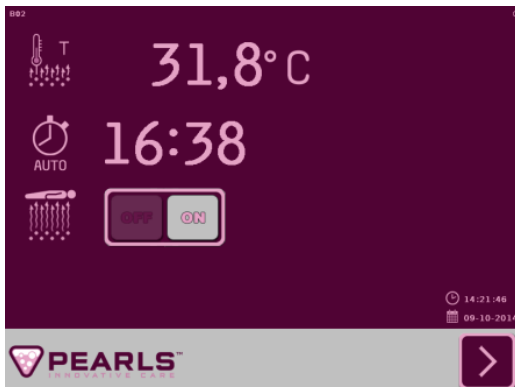



ATTENTION:

The HOME menu displays data for informational purposes only. Settings can be adjusted in the NEXT menu:
PEARLS SANDS



ATTENTION:

Check if the AFCS is at the right temperature when therapy is started. Consult with medical staff for the correct treatment temperature for each patient.



ATTENTION:

The temperature of the AFCS will not be monitored and controlled if the airflow is not activated.

Start the air fan by pressing the hand or foot switch or press.

PEARLS

SANDS

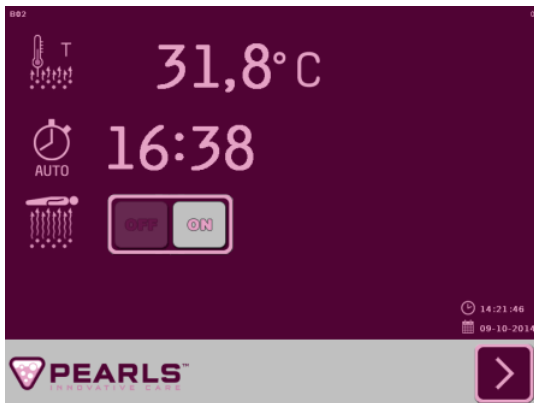

If the temperature is too low/high, the warning  will flash.
The acoustic alarm can be muted by

PEARLS

SANDS





Set temperature as desired. See defined in section “Set Temperature”.

The alarm will remain on as long as the temperature difference between the set temperature and the actual temperature is more than 5,5 °F (3 °C).

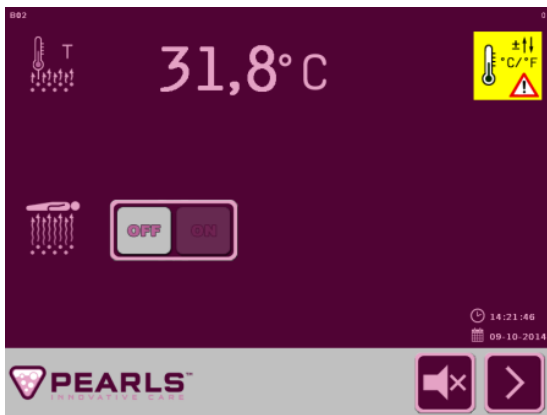
Every 30 minutes the acoustic alarm will be restarted and can be muted as mentioned above.



 The  icon will no longer be visible when the AFCS has reached the set temperature. The AFCS is ready for use.

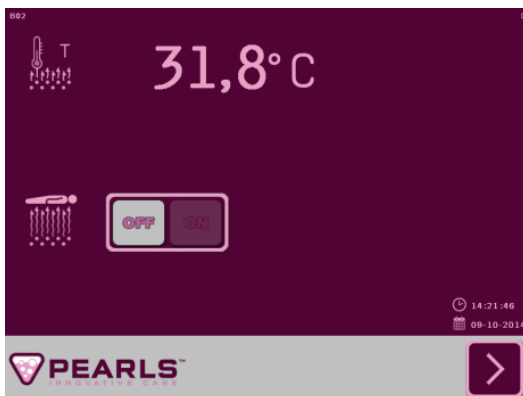

ATTENTION:

If the screen is not touched for some time, the screen saver will appear to prevent damage to the screen. The HOME menu appears immediately upon touch.

Place a regular sheet on the filter sheet. It simplifies nursing and makes the filter sheet less vulnerable to damage from sharp objects.





CAUTION:

Do not remove the filter sheet covering the glass beads. It may only be replaced by skilled service staff as part of the cleaning and decontamination procedure after end the treatment

Set temperature

PEARLS SANDS

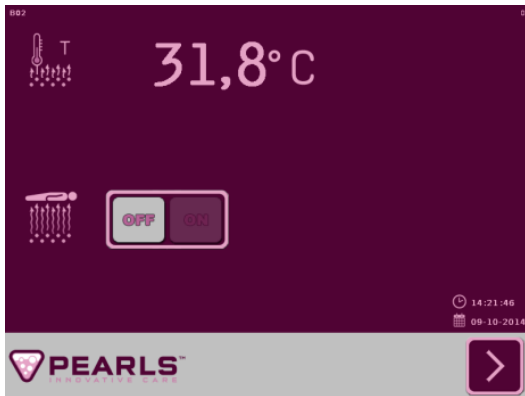

Press   to enter the NEXT menu.

The actual temperature and the set temperature are displayed here.











The actual temperature and the set temperature are displayed here.

PEARLS SANDS

Press the button ,  and keep it pressed. You will reach the secured zone to change the temperature after approx. 10 seconds.



Increase or decrease the requested temperature by pressing   or  

Confirm by   or cancel by  





The temperature can be adjusted between 30°C - 38°C (86°F – 100.4°F)



ATTENTION:
Temperature changes can be made with an accuracy of 1°C (1.8°F)





ATTENTION:
If no button is pressed, it will automatically return to the NEXT menu after 3 seconds

The cooling or heater will be activated according to the new setting and will display  or  in the NEXT menu.



PEARLS SANDS



Pressing   will bring you back to the HOME menu. Otherwise after 5 seconds, it will automatically return to this screen.

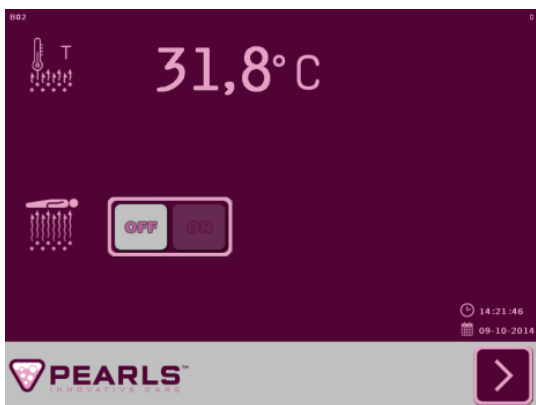

ATTENTION:

Take care the AFCS is set to the right temperature when therapy starts. Consult with medical staff for the correct temperature for each patient.



CAUTION:

The electronics and temperature sensor must be calibrated regularly. Check the service manual for calibration instruction.

Airflow intensity

There are various situations when it is desirable to lower the airflow intensity in the basin permanently. Examples are:

- If the body weight of the patient exceeds 100 kg (220 lbs), the airflow intensity shall be lowered to prevent the patient sinking too much in the glass beads.
- If a patient is treated in a sitting position.
- If the patient is active/mobile and able to move or co-operate in their care.





ATTENTION:

Adequate airflow is needed to keep the interface pressure low and monitored as well as conditioned airflow is circulated around the patient's body to prevent excessive accumulation of moisture.



Adjust airflow intensity:

PEARLS SANDS

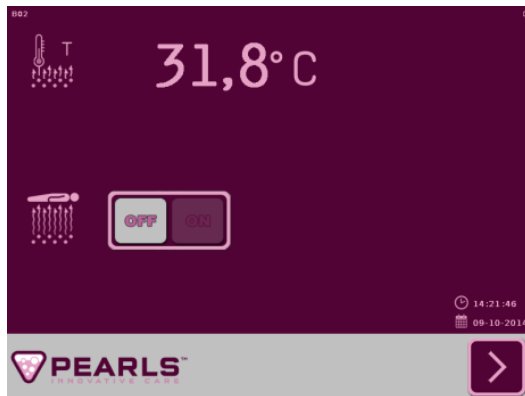

Press   in the HOME menu to enter the NEXT menu. The actual airflow and the set airflow are displayed here.



PEARLS SANDS



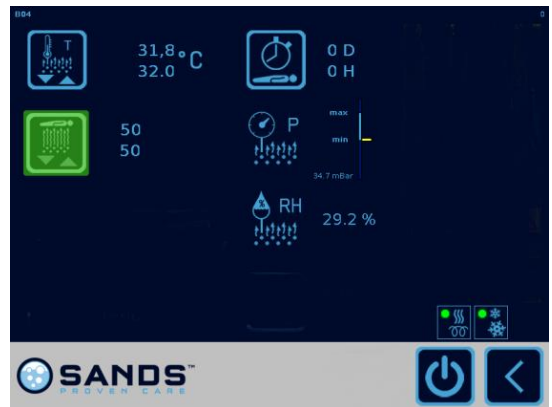

A small graph will indicate the pressure in the AFCS.  

PEARLS SANDS





Press the   button and keep it pressed. You will enter the secured zone to change the airflow intensity after approx. 10 seconds.



PEARLS SANDS PEARLS SANDS

Increase or decrease the requested intensity by pressing   or  

PEARLS SANDS PEARLS SANDS

Confirm by   or cancel by   returns to the NEXT menu.

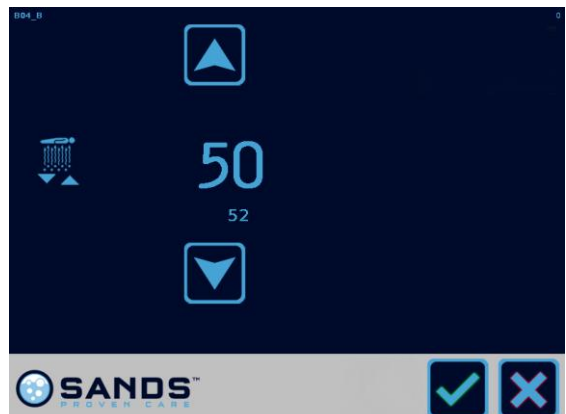
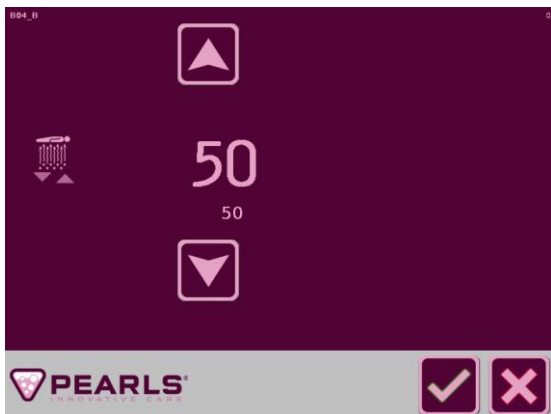

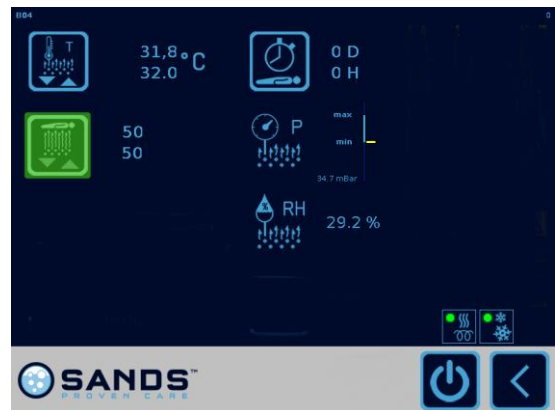

The new set point of the airflow is visible in the NEXT menu.

The airflow intensity can be adjusted between 40 – 55. At 40, the AFCS will be harder due to less airflow and, at 55, the AFCS will be softer due to maximum airflow.



PEARLS SANDS

Pressing   will bring you back to the HOME menu. After 5 seconds, it returns automatically to this screen.

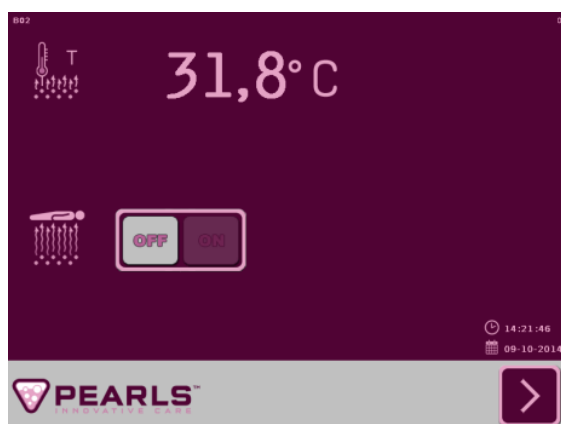

Setting Pulsation (available for PEARLS™ only)

The pulsation provides a cyclic reduction of the airflow intensity in the glass beads. Enough airflow will remain though to keep the patient in contact with conditioned air. The pulsation can be used for various purposes such as:

- To assist patient mobility after a long period of treatment under the direction of the medical staff.
- To keep the patient is immobile for long periods of time.



Pressing  will bring you to the NEXT menu in which the pulsation buttons, if installed, will be visible.



ATTENTION:

It is recommended to program the pulse system when it is not activated.

Set program:

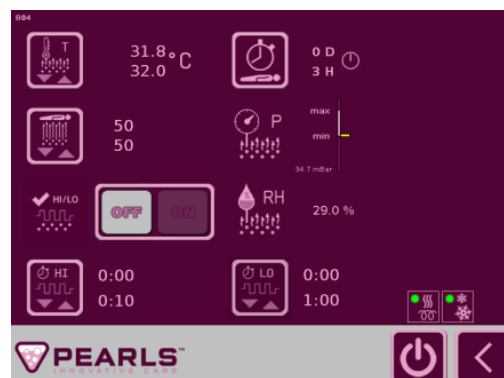

Press  to enter the NEXT menu.
The actual pulsation timers and the set pulsation timers are displayed here.



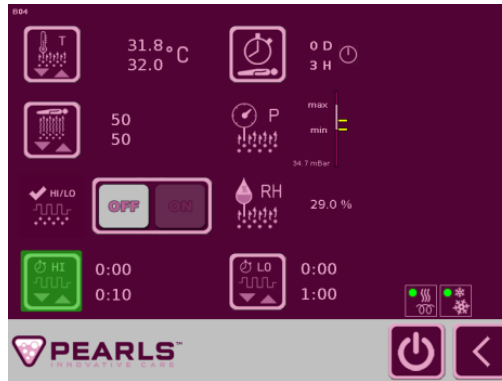

Press the button  and keep it pressed. You will enter the secured zone to change the timer for high pressure after approx. 10 seconds .



Increase or decrease the requested time by pressing  or 



Confirm by  or cancel by 

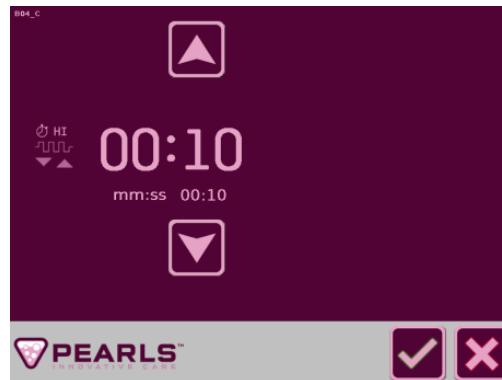



Press the button  and keep it pressed. You will enter the secured zone to change the timer for low pressure after approx. 10 seconds.

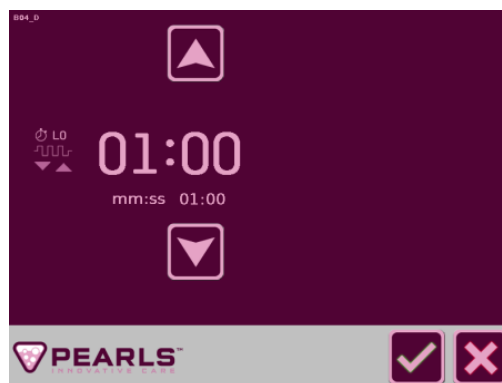
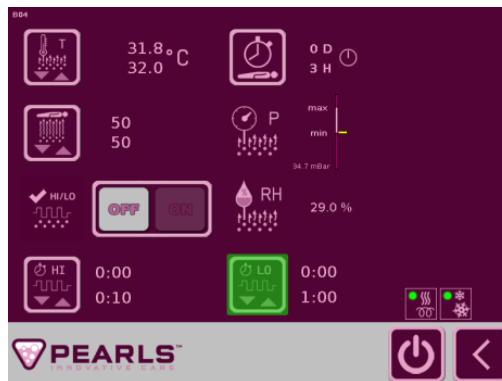

The airflow pulsation can be adjusted between 0 – 10 seconds HIGH pressure and 0 – 10 minutes LOW pressure.

Set points are chosen because of clinical data by the nursing staff only.

The new set points of the pulsation timers will be visible in the NEXT menu.



Pressing  will bring you back to the HOME menu. After 5 seconds, it will return to this screen automatically.





Patient treatment timer

A timer is built into the software to record the patient's AFCS treatment time. You will find the information in the NEXT menu.



PEARLS SANDS





Press the button   and keep it pressed. You will enter the secured zone to start the timer for patient treatment time.







PEARLS SANDS



Pressing the   button will start the timer.



PEARLS SANDS



  will stop the timer.



PEARLS SANDS





  will reset the timer.

PEARLS SANDS

  will confirm the setting and return to the NEXT menu.

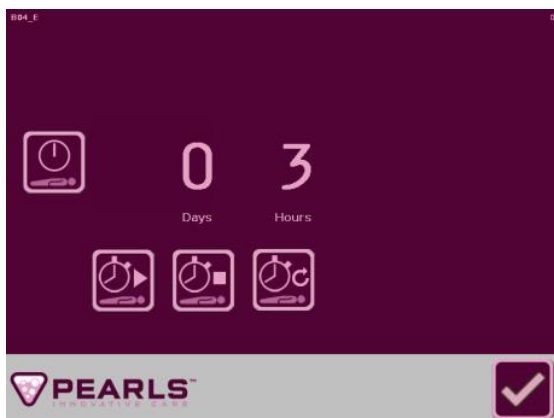

Nursing the patient

A patient lying in an AFCS can easily be moved for nursing or treatment. This chapter describes the nursing process commonly used when treating a patient:

Side position

By turning the patient to the required position using the hospital sheet (while the AFC is activated). Subsequently switching off the air flow (with the hand or foot switch), the patient is safely held and supported in the glass beads. This will make nursing very convenient.

By reactivating the fan, the patient will automatically return to the original position.

Turning the patient to the other side is done in the same way from the other side of the AFC.

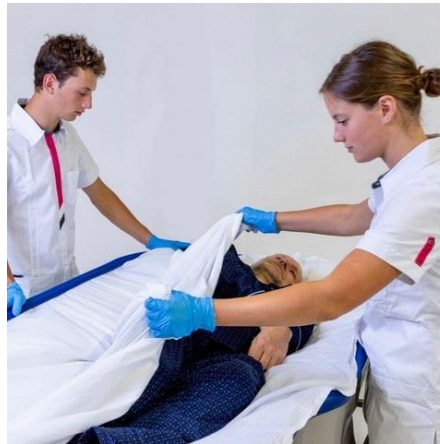

Airflow adjustment for different patient weights

The AFCS offers airflow adjustment to support patients at optimum airflow in relation to their shape and body weight.

The patient should float in a horizontal position without heavier parts of the body sinking deeper (V-positioning).

Attention: the heavier the patient, the lower the airflow should be!

See section **Airflow intensity**

Extra airflow for repositioning

The PEARLS™ AFCS foot switch offers a temporary “REPOSITION” airflow increase.

Activation of the “REPOSITION” foot switch will increase the airflow to a higher level, providing more comfort for nursing while the AFCS will become softer.

After a period, the airflow will automatically return to a normal level, restoring the optimum support for the patient.



CPR

If a patient needs cardiopulmonary resuscitation (*CPR*), immediate intervention is required.

AFCS has a CPR facility located next to the touch screen panel.

By pressing the button, the AFCS will immediately deactivate the airflow to start resuscitation. The touch screen will display a warning.

After the CPR procedure has been finished, the AFTS can be restarted by pressing
PEARLS SANDS



WARNING FOR DANGER:

Remove the backrest in case of a CPR

Fitting a clean sheet

Fitting the hospital sheet is easy using the airflow and the easy turning of the patient in the AFCS.

1. Pull the patient to a side-lying position.
2. Move the soiled hospital sheet towards the patient.
3. Place a clean hospital sheet and stretch it over the AFCS where the patient is not lying.
4. Activate the airflow and turn the patient to the other side.
5. Pull the soiled sheet from the AFCS.
6. Pull the clean sheet underneath the patient's body.
7. Activate the airflow and pull the clean hospital sheet to spread it over the AFCS.



ATTENTION:

It is recommended to change the hospital sheet on a daily basis.

Prevention of “hammock effect”

The filter sheet covering the glass beads is wide to create space for the patient’s body shape into the fluidizing glass beads.

Nursing staff should check regularly to ensure that the filter sheet has not sunk into the glass beads at the centre position as this will create a hard surface, called the “hammock effect”.

This is avoided by pulling the filter sheet (from below the patient) on a regular basis.

The filter sheet remains on the AFCS while treating the patient. It is only replaced after the patient treatment has ended.



Ointments Caution:



CAUTION:

When using wound-healing creams and/or ointments on patients treated in the AFC, check the efficiency of the treatment or (locally) use an “adsorbing” sheet between the patient and the filter sheet



ATTENTION:

It is recommended to use hydrogel pharmaceutical materials and dressings when treating a patient on an AFC



ATTENTION:

It is recommended to use only ventilating absorption materials between the patient and the AFC as the controlled airflow may otherwise not reach the compromised skin



CAUTION:

Below are some of the most common, oil-based products that **shall not be in direct contact with the glass beads** as they will prevent the beads from absorbing the exudates and cause the beads to become greasy, preventing the airflow from being (evenly) distributed.

**Arachis oil
Liquid paraffin
Vaseline
E45 cream
Any oil-based moisturizers
Most steroid creams
Most dermatological creams
Solutions such as Flammazine and Betadine**



CAUTION:

As little as 0.17 – 0.34us fl oz (5 to 10 ml) of any oil-based product will prevent the entire load of glass beads from functioning properly and will destroy the material

For cases of dry skin, an aqueous based emollient should be applied. This has no detrimental effect on the AFCS.



CAUTION:

In case glass beads skip through the filter sheet on the AFC and reach the wound area, it is recommended to clean the area using fresh water

Accessories AFCS

Adjustable backrest (manually adjustable)

The AFCS backrest accessory can be placed in the AFCS without fixation or assembly. It will freely move with the patient during activated airflow to contribute sitting comfort.



AC-BACKREST

Read the instructions before use.



CAUTION:

Always consult the treating physician before use. Service, maintenance, and troubleshooting are to be executed by technically skilled personnel. A service manual is available for these activities



Adjustable footrest (manually adjustable)

The AFCS accessory footrest is adjustable in angle, horizontal position and height. Always consult the treating physician before use.



CAUTION:

Installation, service, maintenance, and troubleshooting are to be executed by technically skilled personnel. A service manual is available for these activities



WARNING FOR DANGER:

Always tighten all bolts and clamps carefully



Traction support pole (including triangle)

Always consult the treating physician before use.



CAUTION:

Installation, service, maintenance, and troubleshooting are to be executed by technically skilled personnel. A service manual is available for these activities



WARNING FOR DANGER:

Maximum SWL on the support pole is 750 N



Traction support frame (including triangle, infusion pole)

Always consult the treating physician before use



CAUTION:

Installation, service, maintenance, and troubleshooting are to be executed by technically skilled personnel. A service manual is available for these activities



WARNING FOR DANGER:

All bolts and clamps should be tightened carefully before use.



WARNING FOR DANGER:

Maximum SWL on the traction support frame is 750 N



Extension hose (maximum 6 m (19.68 ft) in length)

The AFCS can be equipped with the extension hose of up to 6 meters (19.68 ft) in length. This makes it possible to place the control unit at a greater distance from the bed unit.



CAUTION:

Installation, service, maintenance, and troubleshooting are to be executed by technically skilled personnel. A service manual is available for these activities



WARNING FOR DANGER:

Be careful Tripping Hazard!
The extension hose always needs to be connected to the AFCS. Be aware of the hose when approaching.



Alarms and Warnings

Safety Warnings

40°C (104°F) Alarm



WARNING FOR DANGER:

If the AFC becomes warmer than 104°F (40°C), the AFC will be switched off automatically to prevent hazardous situations

When the air temperature in the AFCS rises above 40°C (104°F), a red alert will be displayed as well as an acoustic alarm will sound. This acoustic alarm can be muted with button

PEARLS SANDS



All functions such as airflow, heating, cooling and the (optional) pulsation system will be discontinued.



Intervention of a service engineer is required to check the AFC and investigate or repair the faulty condition before the AFC can be switched on again.

Temperature delta

If the temperature in the AFCS is too low/high, this alarm will flash, and an acoustic alarm will sound.

The alarm will remain on as long as the temperature difference between the set temperature and the actual temperature exceeds 3 °C (5.4°F).

PEARLS



SANDS



Every 30 minutes the acoustic alarm will be restarted; it can be muted by

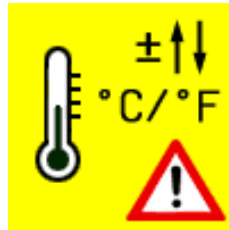

Air pressure drop

If the air pressure in the AFCS is too low, this warning will flash, and an acoustic alarm will sound.

The airflow will be deactivated, and a service engineer is needed to check the AFCS and investigate or repair the faulty condition before it can be switched on again.

PEARLS SANDS



Every 30 minutes the acoustic alarm will be restarted; it can be muted by



Cooler / Heater faulty condition

If the cooler/heater in the AFCS is faulty, this warning will flash in the active menu and an acoustic alarm will sound.

The airflow will be deactivated, and a service engineer is needed to check the AFCS and investigate or repair the faulty condition before it can be switched on again.

PEARLS SANDS



Every 30 minutes, the acoustic alarm will be restarted; it can be muted by



Sensor faulty condition

If a sensor in the AFCS is faulty, this warning will flash in the active menu and an acoustic alarm will sound.

The airflow will be deactivated, and a service engineer is needed to check the AFCS and investigate or repair the faulty condition before it can be switched on again.

PEARLS SANDS



Every 30 minutes, the acoustic alarm will be restarted; it can be muted by



Info warning

If a fault condition is reported within the software, this warning will flash in the active menu.

The airflow may be deactivated and a service engineer is needed to check the AFCS and investigate or repair the fault condition before it can be switched on again.



Service alerts

If the AFCS requires service, these warnings will appear in the active menu.

The AFCS will remain activated, but a service engineer should be notified to maintain the AFC in accordance with the service schedule.

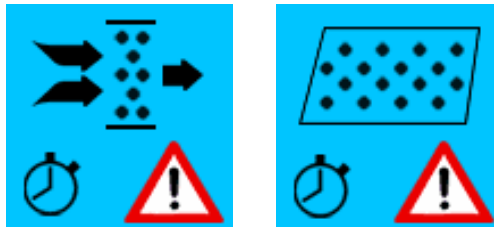

ATTENTION:

Check out the service manual for all service warnings

Cleaning and Decontamination

The AFCS shall be cleaned and disinfected after each patient treatment. This must be done according to strict instructions at a suitable location by authorized and qualified persons.

Decontamination of the AFCS is part of the Service Manual.



ATTENTION:

Cleaning and Decontamination shall be performed before treating each subsequent patient to prevent infection.

Preventive Maintenance



WARNING FOR DANGER:

Preventive maintenance must be performed by skilled service technicians only

This chapter describes when and how service shall be done.

The service department shall keep records and always monitor the counter readings, both at the time of maintenance and upon return of the equipment to the user.

Pre use maintenance



WARNING FOR DANGER:

The AFC shall be disconnected from the main power supply whenever any maintenance is performed.

Air filter

If the AFC needs new air filters, this warning will appear in the active menu.

The AFC will remain activated, but a service engineer should be notified to maintain the AFC in accordance with the service schedule.



Filter sheet

The filter sheet shall be replaced whenever it becomes damaged or heavily soiled. The change of the filter sheet is also part of the cleaning and decontamination instruction for the AFCS.



CAUTION:

Do not allow sharp objects to come into contact with the filter sheet. Scissors, knives etc. can damage it and render it useless. The glass beads will flow off the filter sheet and the basin could fail to operate properly

In the event that the filter sheet is damaged and glass beads are leaking, the following instructions shall be followed:

1. Stop the airflow using the hand/foot switch
2. Switch off the AFCS
3. Report to the service department to request a filter sheet exchange
4. Clean the patient/wounds by washing with water. The glass beads are not harmful and will not cause a hazardous situation.

Condenser

The cooling condenser shall be checked and cleaned at the same time as the air filter is replaced.

Condensation water drain system

The evaporated condensation water is drained from the dehydration unit through a drainage system. This shall be cleaned on a regular base to prevent silting.



ATTENTION:

Check out the service manual for correct operation of service procedures.

Troubleshooting



WARNING FOR DANGER:

If the AFCS displays an alarm or alert, the service department should be notified immediately.

If an unexpected failure or disruption is experienced while treating a patient, rapid action is required to prevent hazardous situations and minimise disruption.

Report the disruption to the service department as soon as possible to have the problem investigated and resolved.

In some cases, the control unit may require replacement. The patient can then remain in the AFCS and usually does not need to be transferred to a new AFCS.



WARNING FOR DANGER:

Hazardous voltages are present in the AFCS. Before accessing circuits and wiring, disconnect the main supply at the main outlet. Do not connect the main supply until all the wiring is complete. All electrical service and repair may be performed only by fully trained and authorized technicians

Appendix PEARLS™

Technical specifications

General

- Adjustable glass beads temperature range $T_b = 30-38\text{ °C}$ (86-100.4 °F), step size 1 °C (1,8°F).
- Best performance at ambient temperatures of $T_a = 25-30\text{ °C}$ (77-86 °F)/ RH55%.
- Dehydration system to control maximum relative humidity of the glass beads at $RH < 40\%$ at maximum ambient humidity of $RH\ 50\%$ at $T_a = 30\text{ °C}$ (86 °F).
- Air volume in the basin infinitely adjustable from $V = 75 - 110\text{ m}^3/\text{hour}$ (2649 – 3885 ft³/hour, controlled by a frequency converter ranged at 40-60Hz.
- Glass beads (sodium calcium glass beads) with solid core and silicon coating. ($\text{SiO}_2\text{-CaO-NaOH-}\% \text{H}_2\text{O}$), diameter $70 - 140\text{ }\mu\text{m}$, standard 550 kg (1212 lbs) per AFCS
- High pH-value (9-11) of the glass beads, minimizing bacteria growth.
- Multifilament mesh $35\text{ }\mu\text{m}$ polyester filter sheet with an elastic rope to connect firmly.
- Infinitely variable high/low position of frame. Minimum height $H = 910\text{ mm} \pm 15\text{ mm}$ ($3.0 \pm 0.05\text{ ft}$), maximum height $H = 1220 \pm 15\text{ mm}$ ($4.0 \pm 0.05\text{ ft}$).
- Integrated and automated heating system for decontamination of glass beads on completion of patient's treatment (optional).
- Detachable control unit with possible extension up to 6 meter (19.7 ft).
- Level adjustment system for optimal fluidization on uneven floors.
- Adjustable pulsation program (reduced air pressure): $t_{\text{active}} = 0-10\text{ sec}$, $t_{\text{fix}} = 0-10\text{ min}$ (optional).
- LED night illumination.

Electrical / Electronic specifications

- 120-230V, 50/60Hz power supply.
- Normal operating power 1700 VA.
- Decontamination operating power 3000 VA (additional power supply).
- Equipotential bonding terminal.
- Integrated decontamination heating elements in basin, $3 \times 1000\text{ W}$, 220-230V, 50/60Hz.
- Hour counters for recording maintenance, operating hours, and service warnings.
- Foot and hand switch for fluidization on/off.
- Foot switch for REPOSITION mode.

Mechanical Specifications

- Total length: 2535 mm (8.32 ft).
- Maximum width: 1150 mm (3.77 ft).
- Inside length of basin 2400 mm (7.87 ft).
- Total system weight: approx. 960 kg (2116 lbs).
- Total weight without glass beads: 410 kg (904 lbs).
- Control unit weight: approx. 110 kg (243 lbs).
- Glass fiber reinforced outer tub.
- Inner basin manufactured in stainless steel 316
- Bed provided with swivel castors for easy transportation, 2 are provided with a brake.
- Control unit detachable and on castors.
- Towing hook for transport.
- Sieve for waste products.
- Actuator for high/low position.

Acoustic specifications

	Without cooling [dBA]	With cooling [dBA]
Patient	41.8	48.8
Operator	44.3	54.0

Appendix SANDS™

Technical specifications

General

- Adjustable glass beads temperature range $T_b = 30-38\text{ °C}$ (86-100.4 °F), step size 1 °C (1,8°F).
- Best performance at ambient temperatures of $T_a = 25-30\text{ °C}$ (77-86 °F)/ RH55%.
- Dehydration system to control maximum relative humidity of the glass beads at $RH < 40\%$ at maximum ambient humidity of RH 50% at $T_a = 30\text{ °C}$ (86 °F).
- Air volume in the basin infinitely adjustable from $V = 75 - 110\text{m}^3/\text{hour}$ (2649 – 3885 ft³/hour, controlled by a frequency converter ranged at 40-60Hz.
- Glass beads (sodium calcium glass beads) with solid core and silicon coating. ($\text{SiO}_2\text{-CaO-NaOH-\%H}_2\text{O}$), diameter 70 – 140 μm , standard 550 kg (1212 lbs) per AFCS
- High pH-value (9-11) of the glass beads, minimizing bacteria growth.
- Multifilament mesh 35 μm polyester filter sheet with an elastic rope to connect firmly.
- Infinitely variable high/low position of frame. Minimum height $H = 910\text{ mm} \pm 15\text{ mm}$ ($3.0 \pm 0.05\text{ ft}$), maximum height $H = 1220 \pm 15\text{ mm}$ ($4.0 \pm 0.05\text{ ft}$).
- Integrated and automated heating system for decontamination of glass beads on completion of patient's treatment (optional).
- Detachable control unit with possible extension up to 6 meter (19.7 ft).
- Level adjustment system for optimal fluidization on uneven floors.

Electrical / Electronic specifications

- 120-230V, 50/60Hz power supply
- Normal operating power 1700 VA
- Decontamination operating power 3000 VA (additional power supply)
- Equipotential bonding terminal
- Integrated decontamination heating elements in basin, 3 x 1000 W, 220-230V, 50/60Hz
- Hour counters for recording maintenance, operating hours, and service warnings
- Foot and hand switch for fluidization on/off

Mechanical Specifications

- Total length 2400 mm (7,87 ft).
- Width: 940 mm (3,08 ft)
- Inside length of basin 2120 mm (6,95 ft)
- Total system weight approx. 940 kg (2072 lbs).
- Total weight without glass beads: 350 kg (772 lbs).
- Control unit weight approx. 105 kg (231 lbs)
- Safe working load 734 kg (1618 lbs)
- Outer tub manufactured in stainless steel 304;
- Inner basin manufactured in stainless steel 316
- Bed provided with swivel castors for easy transportation, 2 are provided with a brake
- Control unit detachable and on castors
- Towing hook for transport
- Sieve for waste products
- Actuator for high/low position

Acoustic specifications

	Without cooling [dBA]	With cooling [dBA]
Patient	53.0	55.0
Operator	58.0	62.0

Appendix AFCS

Technical specifications

Protection

- Safety distances in mechanical construction of ≥ 25 mm (0.082 ft).
- Safety release in spindle motor.
- Easy to access CPR buttons.
- Audible and visual alarms on temperature difference of more than 3 °C (5.4 °F) between set temperature and actual temperature of glass beads.
- Audible and visible alarms for temperatures above >40 °C (104 °F) - deactivation of all functions.
- Automatic restart after 30 minutes on sudden and unexpected failure of power supplies.
- Detection of faulty temperature sensor.
- Detection of faulty pressure sensor.
- Detection of faulty RH sensor.
- Activation of the decontamination elements is not possible without external power supply and releasing the security measurements according to a strict protocol.
- Automatic deactivation of the decontamination heating elements upon failure of the blower.
- Overcurrent protection for the system is provided by fuses.
- Separate fuses for fan, refrigerator unit and heater.
- Hold-to-run control of vertical movement.
- Low power heating element 300W.
- Sound insulating guards / vibration dampers for cooling system.
- Ingress of water: IPX0.
- Automatic monitoring safety circuit (category 2).
- Use of CFC-free coolant in cooling unit

Essential performance

- Temperature control of the air flow blown through the glass beads

Applied Parts

- Basin
- Filter sheet
- Glass beads

None applied parts (regarded as)

- Hand controllers
- Bed frame (top)
- Lifting pole

Operator parts

- Control unit
- Bed frame (bottom)
- Junction box
- Actuator + control box
- Foot switch

Environmental conditions

The AFCS environmental condition limits for use are:

Relative humidity of storage: $30\% \leq RH \leq 70\%$

Temperature of storage: $50^{\circ}\text{F} \leq T \leq 104^{\circ}\text{F}$ ($10^{\circ}\text{C} \leq T \leq 40^{\circ}\text{C}$)

Transport:

AFCS has 3 packaging options:

- Road transport: AFCS on a pallet wrapped with shrinking foil. Note: use a clean truck.
- Air freight: AFCS on a pallet in a wooden box wrapped with shrinking foil.
- Sea freight: AFCS on a pallet in a waterproof wooden box wrapped with waterproof foil.

Standards/Environment

- Electrically tested and approved by DEKRA to EN60601-1
- CE marked according to the MDR (EU 2017/745), Class IIb
- Manufactured under ISO13485 quality assurance
- Basic UDI-DI as referred to in part C of annex VI: 8720387388SATGQ

Accessories (optional parts)

- Traction pole support including patient triangle.
- Traction frame including infusion hook and patient triangle.
- Manually adjustable backrest.
- Adjustable footrest.
- Extension hose (maximum 6 m (19.68 ft) in length).

Service parts (Consumables)

- Filter Sheet: Multifilament / Monofilament fabric in different sizes.
- Air filter.
- Glass beads (sodium calcium glass beads) with solid core and silicon coating, per 25 kg (55 lbs);
- Burn sheet, to prevent pharmaceuticals from entering the glass beads.

APPENDIX Parts PEARLS™

PEARLS™ AFCS main parts list

Item no.	Description	Category
2010001	AFCS PEARLS™ (SAT2) Innovative care, standard 230V, 50 c/s, variable height, safety side rails, temperature control system, adjustable air control, sieve, rubber rim, power supply cable, basin outlet, night illumination, 1 hand switch, 1 foot switch, 2 filter sheets, 2 air filters, without glass beads	product
2010002	AFCS PEARLS™ control unit	product
2010003	AFCS PEARLS™ bed unit	product
2010201	Integrated decontamination PEARLS	option
2010202	Pulsation mode	option
2010317	Kit traction support pole (including triangle)	accessory
2010302	Traction support frame (including triangle, infusion pole)	accessory
2010316	Manually adjustable backrest	accessory
2010304	Adjustable footrest (manually adjustable)	accessory
2022310	Extension hose (maximum 6 m (19.68 ft) in length).	accessory
2010601	Air filter for PEARLS	consumable
2010603	Micro Spherical glass beads 70-140 microns, per 25 kg (55 lbs)	consumable
2010602	Filter sheet for PEARLS LARGE - multifilament	consumable
2010604	Filter sheet for PEARLS SMALL - multifilament	consumable
2010605	Filter sheet for PEARLS LARGE - monofilament	consumable
2010606	Filter sheet for PEARLS SMALL - monofilament	consumable

APPENDIX Parts SANDS™

SANDS™ AFCS main parts list

Item no.	Description	Category
1010401	AFCS SANDS™ (SAT1) Proven care, standard 230V, 50 c/s, safety side rails, temperature control system, adjustable air control, sieve, rubber rim, power supply cable, 1 hand switch, 1 foot switch, 2 filter sheets, 2 air filters, 550 glass beads, 2 buckets each 25 kg spare glass beads	product
1010502	Variable height for SANDS	option
1010501	Integrated decontamination SANDS	option
2010317	Kit traction support pole (including triangle)	accessory
1010702	Traction support frame (including triangle, infusion pole)	accessory
1010716	Manually adjustable backrest	accessory
1010704	Adjustable footrest (manually adjustable)	accessory
2022310	Extension hose (maximum 6 m (19.68 ft) in length).	accessory
1010701	Air filter for SANDS	consumable
2010603	Micro Spherical glass beads 70-140 microns, per 25 kg (55 lbs)	consumable
1010705	Filter sheet for SANDS LARGE - multifilament	consumable
1010706	Filter sheet for SANDS SMALL - multifilament	consumable
1010707	Filter sheet for SANDS LARGE - monofilament	consumable
1010708	Filter sheet for SANDS SMALL - monofilament	consumable